

REF	PART NO.	VALUE	DESCRIPTION
1A	15262 (H-1)	0.1 / 150v	1st RF bias bypass
1E	15262 (H-1)	0.1 / 150v	1st RF screen bypass
1F	15262 (H-1)	0.1 / 400v	2nd-3rd RF screen bypass
1H	15262 (H-1)	0.1 / 400v	RF plate circuit bypass
2B	16233 (H-4)	0.1 / 150v	RF bias bypass
2C	16233 (H-4)	0.1 / 150v	2nd AF bias bypass
2L	16233 (H-4)	0.01 / 400v	AC line bypass (2 each)
3D	16745 (H-7)	0.3 / 150v	Det bias bypass
3M	16745 (H-7)	.075 / 400v	Det 1st AF coupling condenser
3P	16745 (H-7)	250 pfd / 400v	Phone condenser
4	15160	6000 / 10000	Volume control
5	16235	1500	1st RF bias resistor
6	16988	160	RF bias resistor
7	17041	3000 / 3000	Bleeder Resistor #1
8	15660	1050	Bleeder Resistor #2
9	16788	28 pfd	Loc/Dist switch condenser
10a	14340	2 / 450v	Filter condenser #1
10b	14340	2.3 / 450v	Filter condenser #2
10c	14340	0.5 / 400v	1st AF filter condenser
10d	14340	1.0 / 400v	Det filter condenser
10e	14340	2.3 / 450v	Filter condenser #3
10f	14340	0.1 / 400v	1st AF bias bypass
11	Black-Yellow	150,000	Det bias resistor
12	Black	65,000	Det coupling resistor
13	Black	65,000	Det filter resistor
14	Blue	100,000	1st AF grid leak
15	15660	1050	1st AF bias resistor
16	Gray	30,000	1st AF filter resistor
17	Note 1	0.01 / 600v	Quality condenser
18	White	40,000	2nd AF bias resistor #2
19	Black	65,000	2nd AF bias resistor #1
20	17077	5 + 5	Filament shunt resistor
21	15747	2	Dial light resistor
22	16659 ²	-	RF Plate Choke #1 #2 #3
23	15271	-	Det plate RF choke
24	?	?	1st stopping condenser
25	?	?	2nd stopping condenser

Notes
1 - Quality condenser is mounted inside the audio output transformer.
2 - Part number is believed to be correct but unconfirmed.

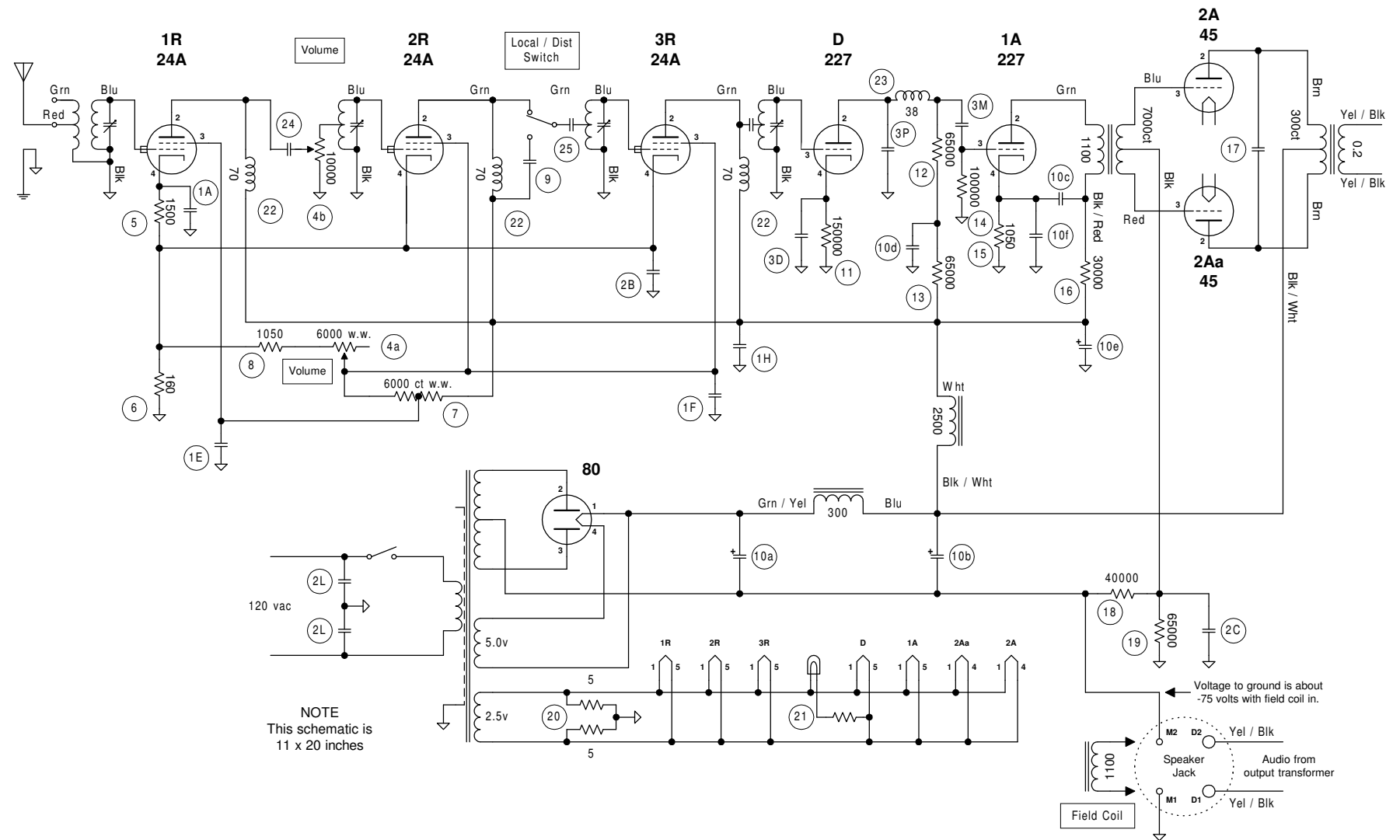

NOTE
This schematic is
11 x 20 inches

Voltage Table

Element \ Tube	1R	2R	3R	D	1A	2A
Plate	170	175	175	110	75	250
Screen	130	96	96			
Grid	-8	-4	-4	-12	-2	-48

All voltages measured from tube cathode (-F for 2A & 2Aa), volume at maximum.
Taken with 1000 ohm-per-volt meter at 120 volt line. Reduce by 9% for 110 volt line.

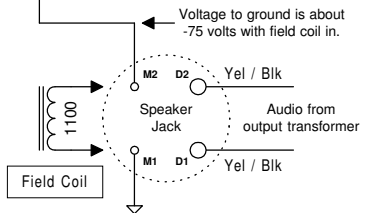

PRELIMINARY
The data presented herein is believed to be correct, but is subject to revision as new information becomes available.

This drawing covers models: 60 15500 60C 15100		W3NLB		(c) 2003-2007 W3NLB All Rights Reserved	
Atwater Kent Model 60 & 60C (late)					
Schematic Diagram					
Drawn by: Leigh Bassett W3NLB	Size B	FSCM NO	DWG NO AK15001SCHEM	REV C	
Date: 15 Feb 2007	SCALE			SHEET 1 OF 1	